

MOBILE JAW CRUSHER

THE **2950j-t** OFFERS CLASS-LEADING THROUGHPUT



Maximum productivity is delivered through the 50" x 29" single toggle jaw with speeds that lead to better reduction and material being processed faster through the crushing chamber. This plant has enhancements to the jaw box including heavier flywheels and optimization for all crushing applications. With a class-leading throughput, capacity and largest stockpile height in its category, the 2950j-t brings even more power and productivity together in one machine.

-
- 50" x 29" single toggle jaw
 - 350Hp C9/C9.3 Cat engine
 - Track or track c/w wheel bogie
 - Integrated hydraulic folding hopper
 - Integrated hydraulic folding stockpiling conveyors
 - I-beam plate fabricated chassis construction
 - Large gap between crusher discharge and main conveyor feedboot
 - Open chassis design for ease of maintenance
 - Fast setup time

LIPPMANN

2950j-t TECHNICAL SPECIFICATIONS

SPECIFICATIONS	
Jaw Crusher	29" x 50"
RPM	280 rpm
Feed Size	2.5"
Discharge Conveyor	48"
Discharge Conveyor Operating Speed	109 rpm
Feeder	50" x 29"
Feeder Operating Speed	280 rpm
Grizzly Length	56.2"

HORSEPOWER	
Diesel	C93.3
Diesel HP	350 hp
Jaw	116.2 gpm
Grizzly Feeder	16.6 gmp
Side Discharge (optional)	11.5 gpm
Discharge Conveyor	23.1 gpm
Diesel Tank Capacity	221 gal
Hydraulic Tank Capacity	475 gal

TRACK	
Width	19.7"
Length	12' 6"
Height	31.4"

TRANSPORTATION	
Weight	112,435

HYDRAULIC TOGGLE OR MANUAL TOGGLE PLATE AVAILABLE [CLOSED SIDE SETTING (CSS) INCHES]	
2.5	221
3	250
3.5	273
4	305
5	345
6	380

* Manual toggle plate option only.

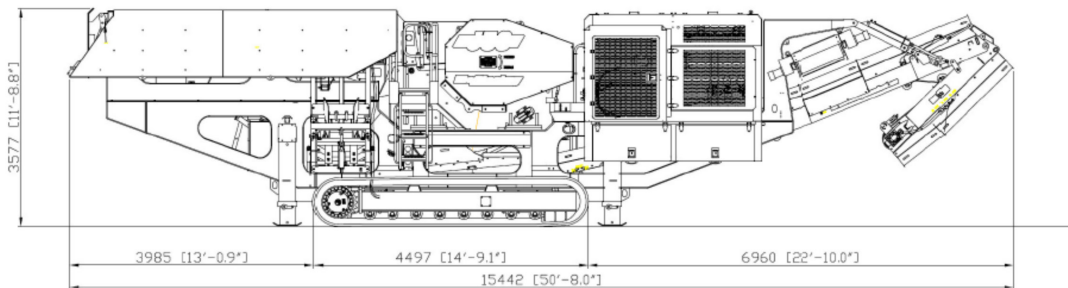
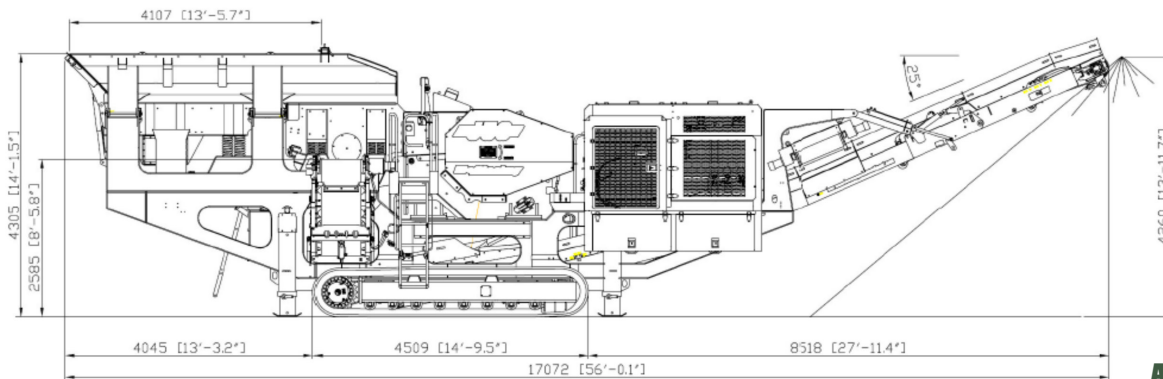

ADDITIONAL OPTIONS

- Pre-Screen
- Hopper Extensions
- Overband Magnet
- Water Pump/Dust Suppression System
- Diesel Refueling Pump
- Closed Circuit Option

AUTHORIZED DISTRIBUTOR

LIPPMANN

3271 East Van Norman Avenue
Cudahy, WI 53110

Lippmann-Milwaukee.com

800-648-0486