

DUAL POWER SCREENER

THE **L516r** SCREENER GIVES A CLEAN END PRODUCT



One of the most versatile screeners, the L516r High Energy Screener is available in several configurations including Dual Power, and is a tough, robust screening tool designed to cope with the heaviest of applications. The L516r Dual Power brings versatility to any site, while reducing operational costs and CO₂ emissions. With the ability to handle some of the worst, untreated construction and demolition waste, the L516r can minimize material pre-handling and provide clean end products. The L516r has proven to be extremely effective across a wide range of applications. With a screening area of 155 ft² across the High Energy Screenbox – the largest in its class – the L516r has impressed operators working with difficult materials. The L516r dual power screener incorporates both diesel and electric power options, providing flexibility in selecting the most appropriate power source for a given situation. The ability to switch between diesel and electric power reduces fuel consumption, lowers operating costs, and minimizes environmental impact.

- 4.880m x 1.525m (16'x5') heavy duty high energy 2 bearing screenbox
- Travel out fixed walkways
- Direct feed Hardox® lined hopper
- 97 kW (127 Hp) diesel engine
37 kW (50 Hp) electric motor
- Integrated hydraulic folding stockpiling conveyors
- Track mobile
- Fast on site setup time – 10 minutes
- Screen raises at lower end for easy bottom deck access
- Service standing room inside Powerpac

LIPPMANN

L516r TECHNICAL SPECIFICATIONS

TRANSPORT	
Transport height	3.40m (11' 2")
Transport length	15.3m (50' 2")
Transport width	2.90m (9' 6")
Weight - belt feeder	32,700 Kgs (72,091 lbs)
Weight - apron feeder	35,420 Kgs (78,090 lbs)

ENGINE	
Diesel electric or dual power hybrid	130 Hp (97 kW)

SCREENBOX	
Top deck	4.880m x 1.525m (16' x 5')
Bottom deck	4.575m x 1.525m (15' x 5')

STOCKPILE HEIGHT	
Tail conveyor	3.75m (12' 3")
Fines conveyor	3.96m (13')
Mid conveyor	3.60m (11' 10")

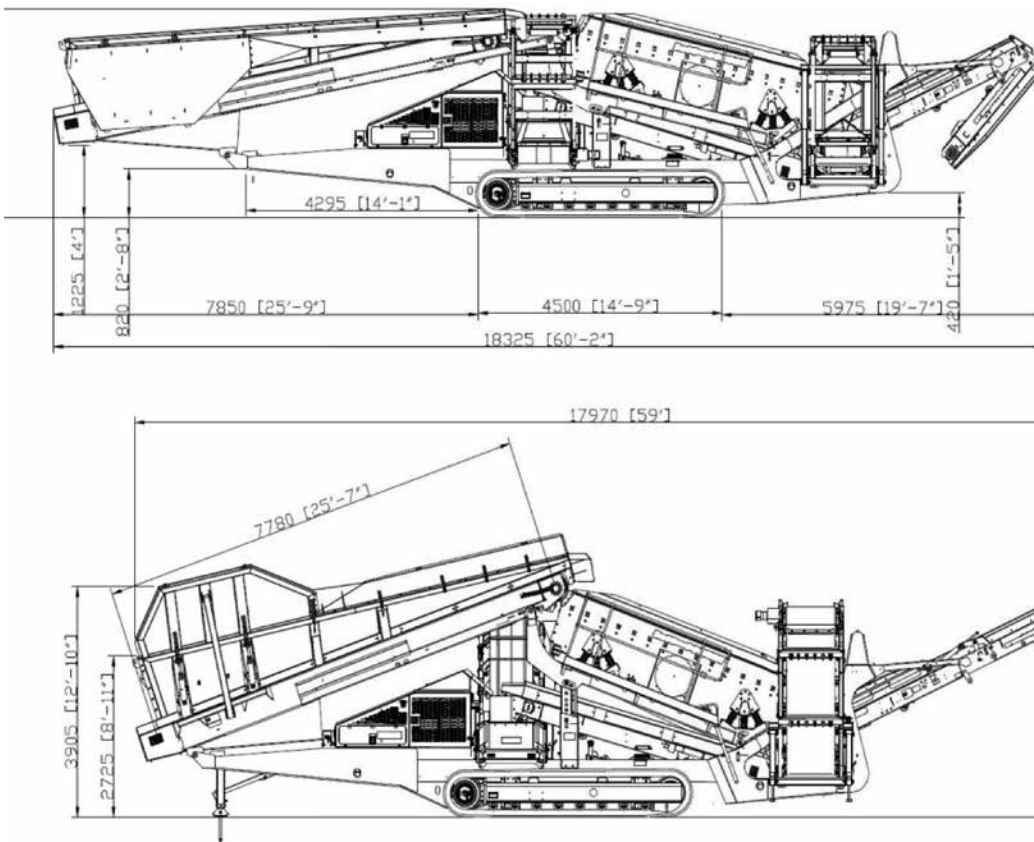

ADDITIONAL OPTIONS

- Heavy duty top deck finger screen
- Bottom deck finger screen
- Top deck punch plate
- Bottom deck punch plate
- Top deck Bofor screen
- Radio remote control for tracks
- Plate apron feeder

AUTHORIZED DISTRIBUTOR

LIPPMANN

3271 East Van Norman Avenue
Cudahy, WI 53110

Lippmann-Milwaukee.com

800-648-0486