

## TRACKED STACKER

# THE **80st** OFFERS ON-SITE TRACK MOBILITY



The Lippmann 36" x 80' Tracked Stacker has been designed for high capacity stockpiling operations with on-site track mobility. All units come as standard with diesel power units, hydraulic main lift and hydraulic top fold for a fast on-site setup time. Electric and dual power are available as options based on the best application for the customer's business. The LTS line is equipped with a radio-controlled track mounted unit. This heavy duty mobile stacker has a 22.5 degree max conveyor angle allowing for the highest stockpiles per conveyor length in the industry. With its durable truss frame, large feed hopper and production capacity up to 800 TPH, the Lippmann LTS80 stacks up well above the competition. Available with numerous custom options offered to meet each customer's unique requirements.

- 900 mm (36"Ø wide heavy duty 80' long conveyor
- 36.5kW (49 hp) diesel engine
- On-site track mobility
- Large feed hopper
- Hydraulic folding frame for easy transport
- Fast on-site setup time (5 minutes)
- Abundant service room inside the power-pack
- Adjustable hopper height to optimize operational efficiency

# LIPPMANN

# 80st TECHNICAL SPECIFICATIONS

SPECIFICATIONS	
Belt Width	36" (900mm)
Belt Length (Pulley Centers)	80' (24,380mm)
Belt Type	Heavy Duty Plain 3-Ply, 3/16" x 1/16"
Drive Pulley Diameter	14" (355mm)
Tail Pulley Diameter	12" (304mm)
Maximum Belt Speed	548 ft/min. (167 m/min)
Maximum Conveyor Capacity	500 TPH
Diesel Engine Size	49 hp (36.5 kW)
Diesel Tank Capacity	87 US Gallon (330 L)
Hydraulic Tank Capacity	116 US Gallon (440 L)

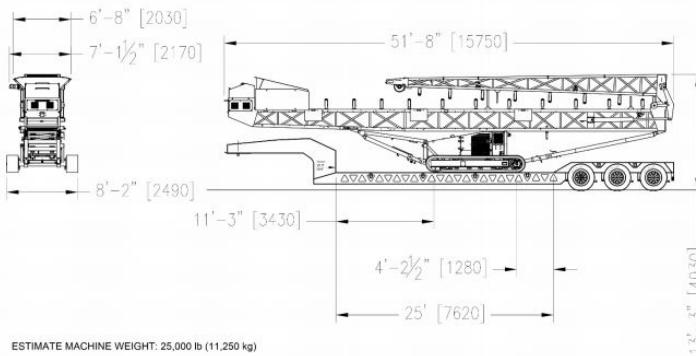

WORKING DIMENSIONS	
Width	8' 2" (2,490 mm)
Length	82' 9-1/2" (25,240 mm)
Height	32' 5" (9,880 mm)

TRACK SPECS	
Track Width	1' 3-3/4" (400 mm)
Track Length (Center-to-Center)	8' 1" (2,470 mm)
Track Height	2' 5" (594 mm)
Maximum Speed	0.75 mph (1.2 km/hr.)

WORKING DIMENSIONS (WITH LIFT AXLE OPTION)	
Width	20' 4" (6,200 mm)
Length	84' 5" (25,730 mm)
Height	35' 1" (10,690 mm)

TRANSPORT DIMENSIONS	
Width	8' 2" (2,490 mm)
Length	51' 8" (15,750 mm)
Height	11' 3" (3,420 mm)
Total Weight (approximate)	25,000 lbs (11,400 kg)

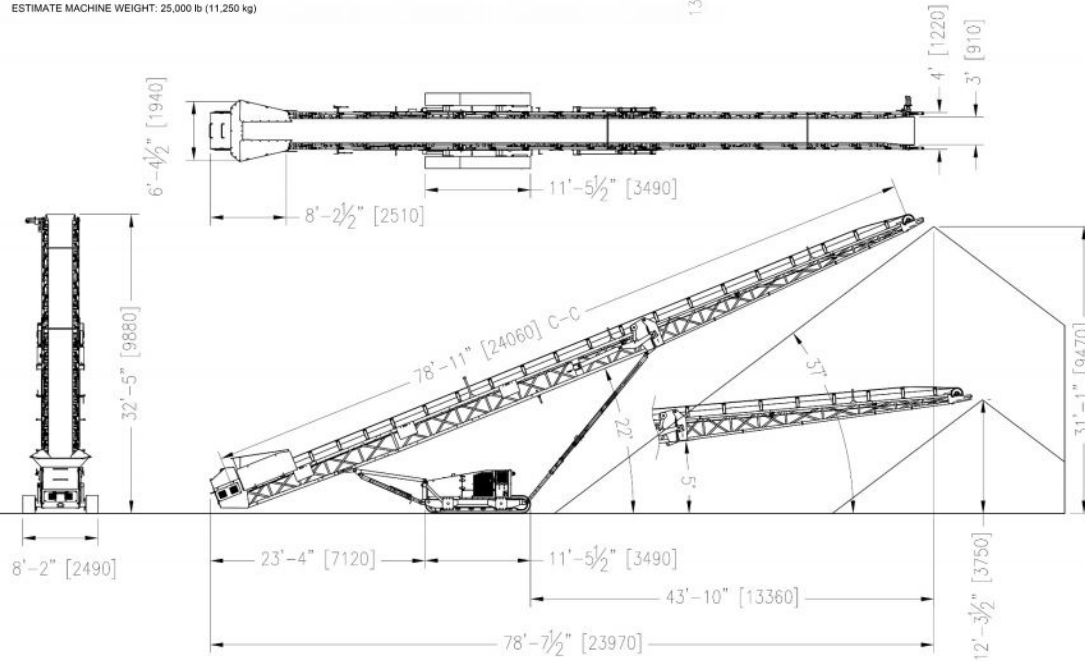

## ADDITIONAL OPTIONS

- Landing gear
- Belt scale
- Spray bar
- Chevron belt
- ASGCO scraper
- Impact idlers under hopper
- Lift axle
- Magnet material separator
- Anti-segregation paddle wheel
- Auxiliary guarding
- Hopper wing plates
- Hopper wear plate liner
- TimBin - large hopper bin (450tph)

AUTHORIZED DISTRIBUTOR

# LIPPMANN

3271 East Van Norman Avenue  
Cudahy, WI 53110

Lippmann-Milwaukee.com

800-648-0486