

BENEFITS OF ELECTRIC

Increased reliability: dual-powered plant can run off diesel until site is more established for electric

Economically beneficial: easily switch from 400 kVA generator to electric mains operation

Environmentally sound: produce material with little possibility of environmental impact

Hybrid flexibility: the choice to select the most economical power source is always in your hands



THE LIPPMANN EDGE

The dual-powered operation on this model is the latest in a long line of Lippmann innovation since 1923. Designed with the customer in mind, these electric jaw crushers cost less to run while taking reliability to new levels. Hybrid power offers flexibility and makes it possible to always select the most economical power source.

- Connect to line power or on-board generator
- Electrical connections provide simplified troubleshooting
- Push-button control of jaw, track, and feeder functions



**SAFETY AT EVERY STEP,
FROM THE FACTORY FLOOR
TO THE JOB SITE.**

STANDARD SAFETY FEATURES:

- Engine safety shutdown systems
- Full safety guarding on all nip points
- Tagout capability on isolator
- External belt alignment points
- External grease points
- Startup siren with 10-second delay
- Emergency stops: 4 off, 2 feeder, 2 power unit

1300j HYBRID TRACK-MOUNTED JAW CRUSHER PLANT

TRANSPORTATION		
	US	METRIC
Length	55' 0"	16.7
Width	11' 6"	3.5m
Height	12' 10"	3.9m
Feeder Section Weight	135,000 lbs	61,000kg
Chassis Section Weight	104,000 lbs	47,000kg
Total Weight	239,000 lbs	108,000kg

CHASSIS SECTION TRANSPORTATION

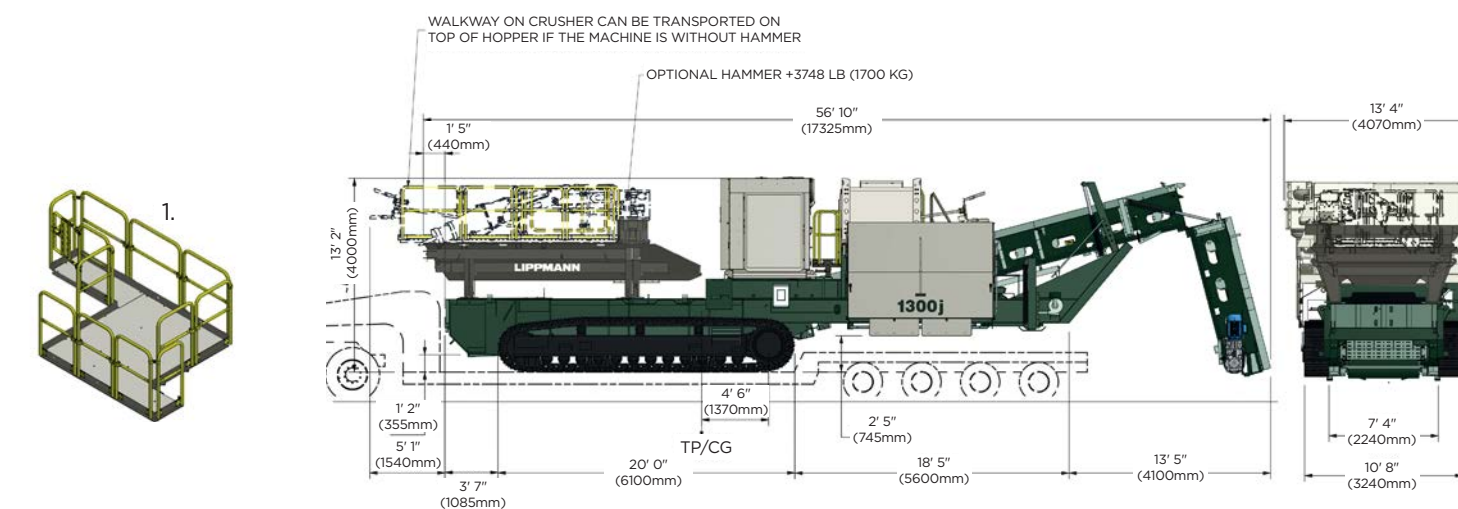

FEEDER SECTION TRANSPORTATION

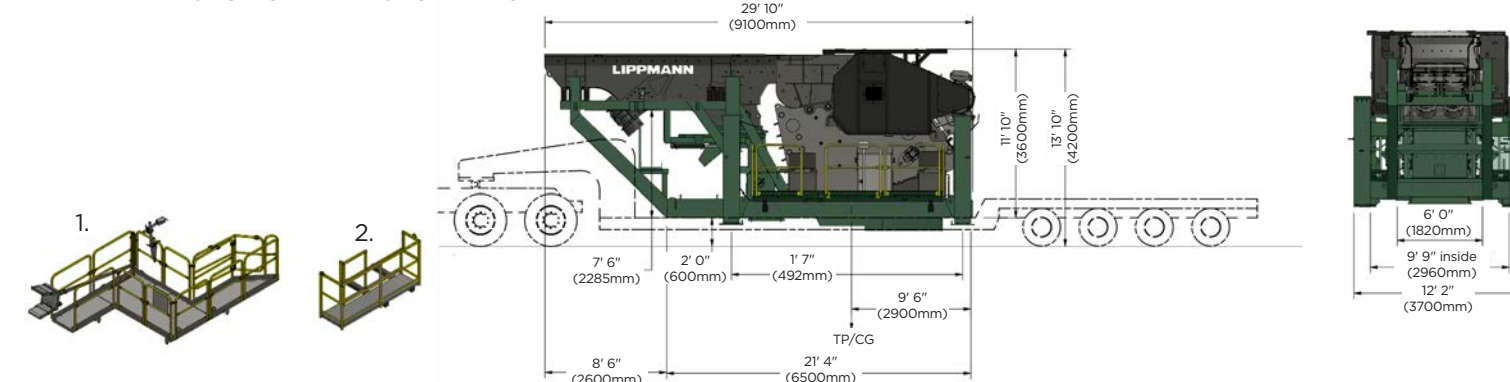

Technical Specifications Subject to Change

LIPPMANN

3271 East Van Norman Avenue
Cudahy, WI 53110
Lippmann-Milwaukee.com
800-648-0486

AUTHORIZED DISTRIBUTOR

HYBRID TRACK-MOUNTED JAW CRUSHER PLANT

THE **1300j** USES
HYBRID POWER FOR
ULTIMATE FLEXIBILITY.



LIPPMANN

Hybrid Track-Mounted Jaw Crusher Plant 1300j

Utilizing smart design with high operational reliability, the 1300j conveniently switches from generator to electric mains so you can always select the most economical power source. When alternating between diesel and electric, you'll always enjoy stable, efficient production with little environmental impact.

An impressive 51" x 39" crushing jaw features a large intake that accepts some of the largest of mining and aggregate material in the industry. A central dashboard is designed for easy monitoring of your most relevant machine data.

Transport weight is kept as minimal as possible thanks to the plant's ability to separate into two parts—also a key benefit for accessibility when service or maintenance is required.

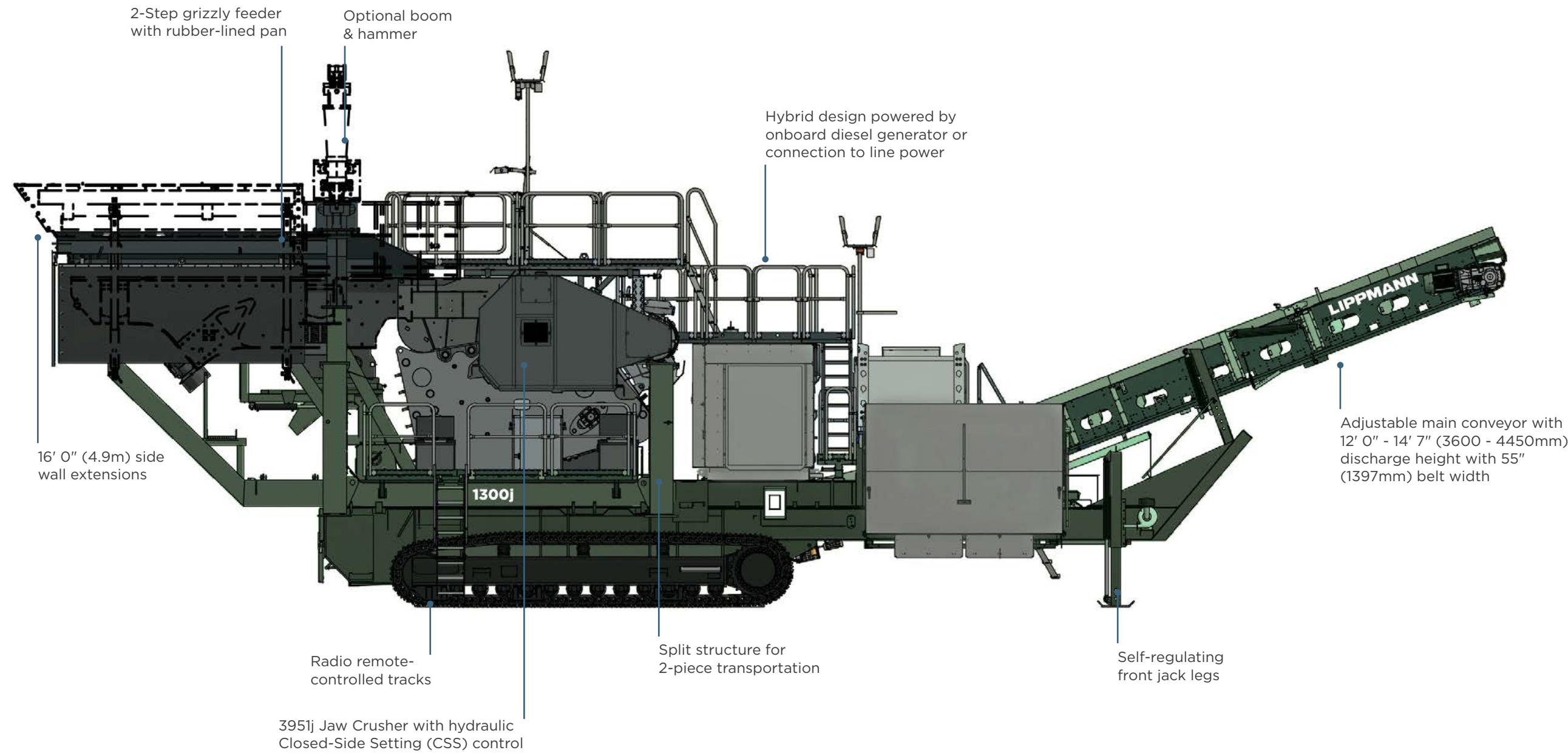

SPECIFICATIONS		
	US	METRIC
Jaw Crusher	3951j	3951j
Feed Opening (WxD)	51" x 39"	1300mm x 1000mm
CSS	4" - 11"	100 - 280mm
Tons Per Hour	300 - 915 STPH	270 - 830 MTPH
Operating Speed	220 rpm	3.67 Hz
Stroke	1-5/8"	41mm
Feed Size	32"	800mm
Discharge Conveyor Height	12' 0" - 14' 7"	3600 - 4450mm
Discharge Conveyor Length	59'	18000mm
Discharge Conveyor Width	55"	1400mm
Discharge Conveyor Operating Speed	4.2 ft/s	1.3 m/s
Feeder	JF 1250 with grizzly	JF 1250 with grizzly
Feeder Dimensions	16' 5" x 3' 10"	5000mm x 1200mm

POWER UNIT AND ELECTRICS/HYDRAULICS		
	US	METRIC
Engine	Volvo TAD 1382GE, EU Stage V	Volvo TAD 1382GE, EU Stage V
Generator	Stamford 400kVA	Stamford 400kVA
Diesel Tank	766 US Gal	2900L

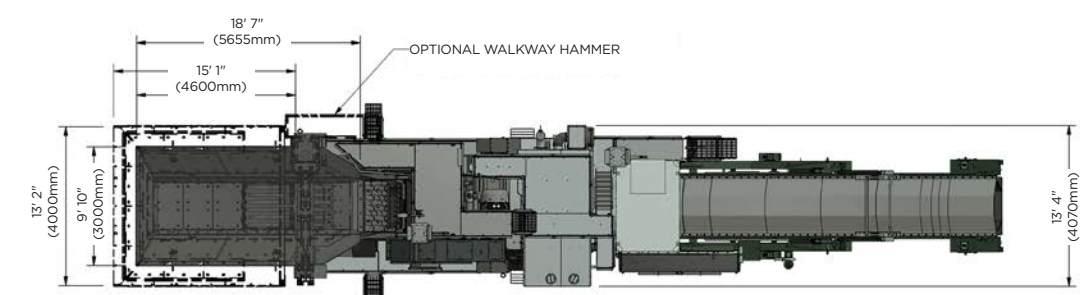
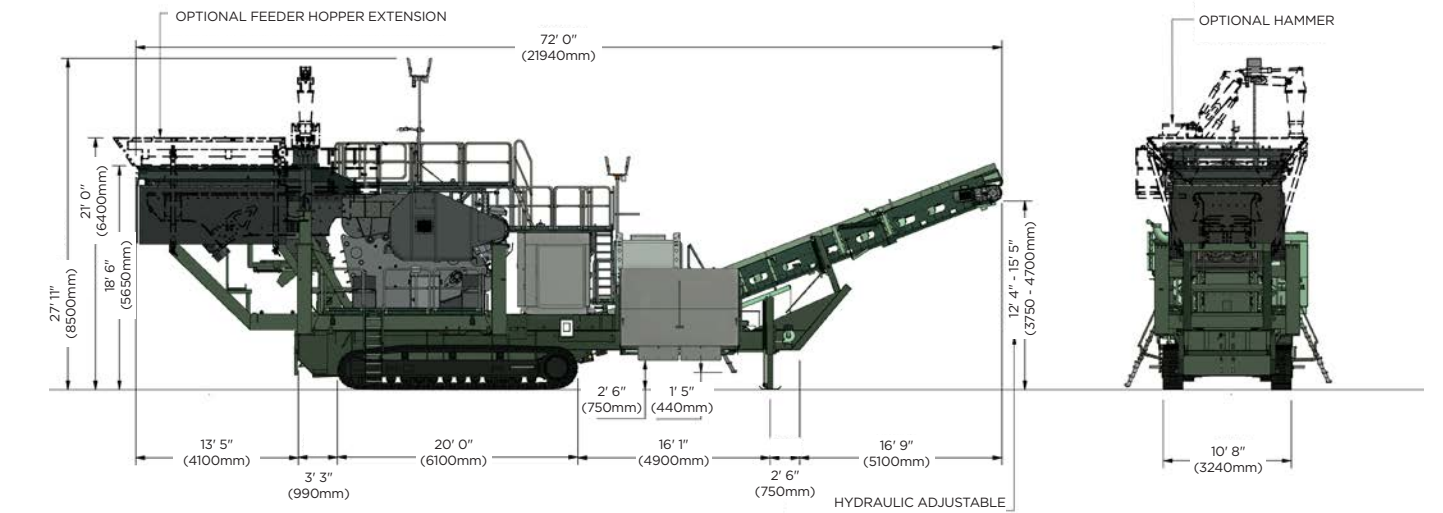

JAW STANDARD FEATURES

- 51" x 39" Jaw opening
- Hydraulic closed side setting adjustment
- JF 1250 feeder with 2-step grizzly
- Hopper and chutes lined with wear plates
- Telematics control system with 10" (254mm) screen
- Adjustable conveyor under the crushing chamber
- Emergency stops on strategic locations on the unit

- Ladders, stairs, platforms with rails at necessary places
- Jobsite lights with 230V LED, and 24V LED spotlight
- Ground-level diesel tank access for Genset
- Electric control cabinet with PLC monitoring and PC
- Self-regulating front jack legs
- Radio-controlled tracks

OPTIONS

- Longer 20' 0" (6000mm) feeder available
- Advanced telematics
- Electronics prepared for main supply
- Belt scale
- Ultrasonic cavity level sensor
- Magnetic separator
- Water spraying
- Air compressor



Hybrid power solution offers flexibility and makes it possible to always select the most economical power source.



The 1300j's 3951j jaw structure is pinned and bolted with no welded parts. Features a CSS of 4" - 11" (100-280mm) and hydraulic adjustment.



Standard telematic control system delivers machine data to a central dashboard for convenient monitoring of belt scales, automation system, generator/engine, and alarm logs and diagnostics.