

HIGH PRODUCTION SCREENER

THE **L520S-T** IS TOP CHOICE FOR QUALITY AND VALUE



The most advanced and innovative 20'x5' portable vibratory screening plant today is the L520s-t. Featuring adjustable screen box angles allowing adaptability to a wide range of material applications including quarrying, mining, sand and gravel, coal screening, topsoil and woodchip. With the highest-grade specifications and component parts, and offering a triple deck makes this screener a top choice for high productivity, quality and value.

- 20x5 heavy-duty, high energy, 2-bearing 3-deck screenbox
- 125Hp Cat engine
- Track or wheel mobile
- Integrated hydraulic folding stockpiling conveyors
- 3-deck auxiliary conveyor attaches to the machine for one unit transport
- Remote control tipping grid
- Fast on-site setup time - 15 minutes

LIPPMANN

L520S-T TECHNICAL SPECIFICATIONS

SPECIFICATIONS	
Length - transport 15ft hopper	18.45 (60'-6")
Length - transport 12ft hopper	17.54m (57'-6")
Width - 500mm wide conveyor	3.06m (10')
Width - 650mm wide conveyor	3.22m (10'7")
Height - transport track	3.45m (11'-4")
Weight - track	36,500 Kgs (80,468 lbs)

SCREENBOX	
Dimensions - top deck	6100mm x 1524mm (20'x5')
Dimensions - middle deck	6100mm x 1524mm (20'x5')
Dimensions - bottom deck	5490mm x 1524mm (18'x5')
Screens - top deck	5'x4' side tension - 5 off
Screens - middle deck	5'x4' side tension- 5 off
Screens - bottom deck	5'x6' end tension - 3 off

CONVEYORS	
Side conveyor - stockpile height - track model	5100mm (16'-9")
Side conveyor - belt width	800mm (32")
3 deck transfer conveyor - belt width	650mm (26")
Feed conveyor - belt width	1200mm (48")
Main conveyor - belt width	1050mm (42")
Tail conveyor - stockpile height - track model	4638mm (15'-3")
Tail conveyor - belt width	1200mm (48")
3 deck auxilliary conveyor - stockpile height - track model	4700mm (15.5')
3 deck auxilliary conveyor - belt width	650mm (26")

POWER UNIT & HYDRAULICS	
Engine	CAT 4.4 (Tier III)
Engine power	125 HP
Engine speed	2200 rpm

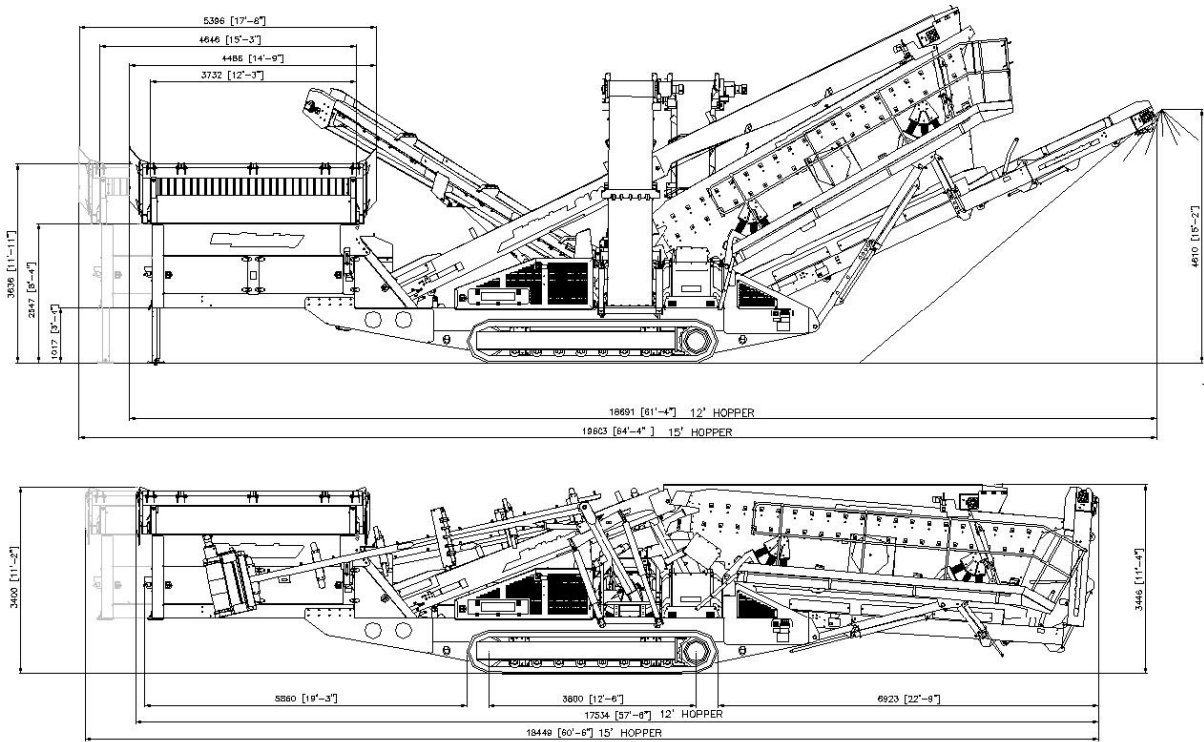

AUTHORIZED DISTRIBUTOR

LIPPMANN

3271 East Van Norman Avenue
Cudahy, WI 53110

Lippmann-Milwaukee.com

800-648-0486