

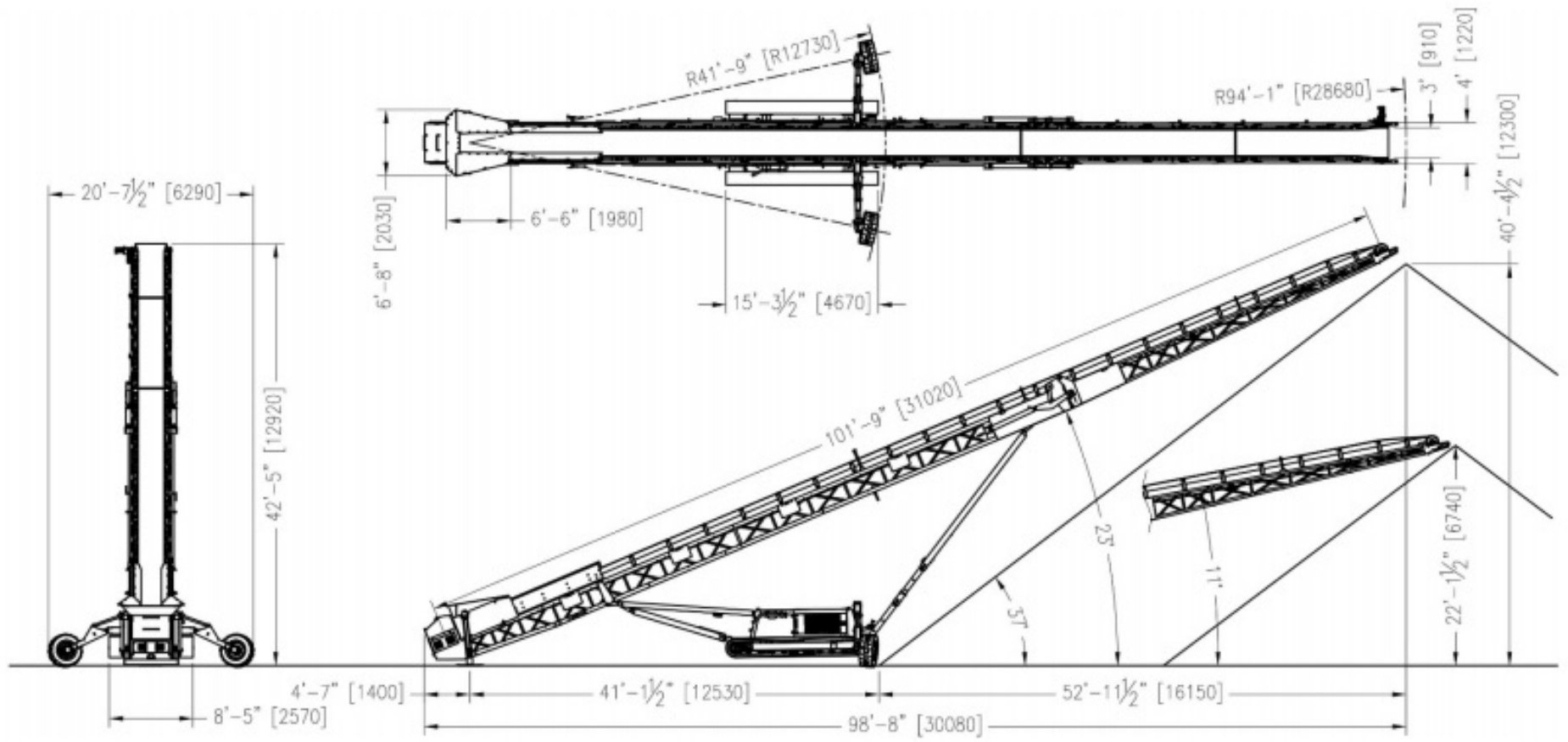

LTS100 TRACKED STACKER

The Lippmann 36" x 100' Tracked Stacker has been designed for high capacity stockpiling operations with on-site track mobility. All units come as standard with diesel power units, hydraulic main lift and hydraulic top fold for a fast on-site setup time. Electric and dual power are available as options based on the best application for the customer's business. The LTS Line is equipped with a radio-controlled track mounted unit. This heavy duty mobile stacker has a 22.5 degree max conveyor angle allowing for the highest stockpiles per conveyor length in the industry. With its durable truss frame, large feed hopper and production capacity up to 800 TPH, the Lippmann LTS-100 stacks up well above the competition. Available with numerous custom options offered to meet each customer's unique requirements.

- 900 mm (36") wide heavy duty 100' long conveyor
- 55 kW (74 hp) T4F diesel Engine
- On-site track mobility
- Large hopper
- Hydraulic folding frame for easy transport
- Fast on-site setup time (5 minutes)
- Abundant service room inside power-pack
- Adjustable hopper height to optimize operational efficiency



LTS100

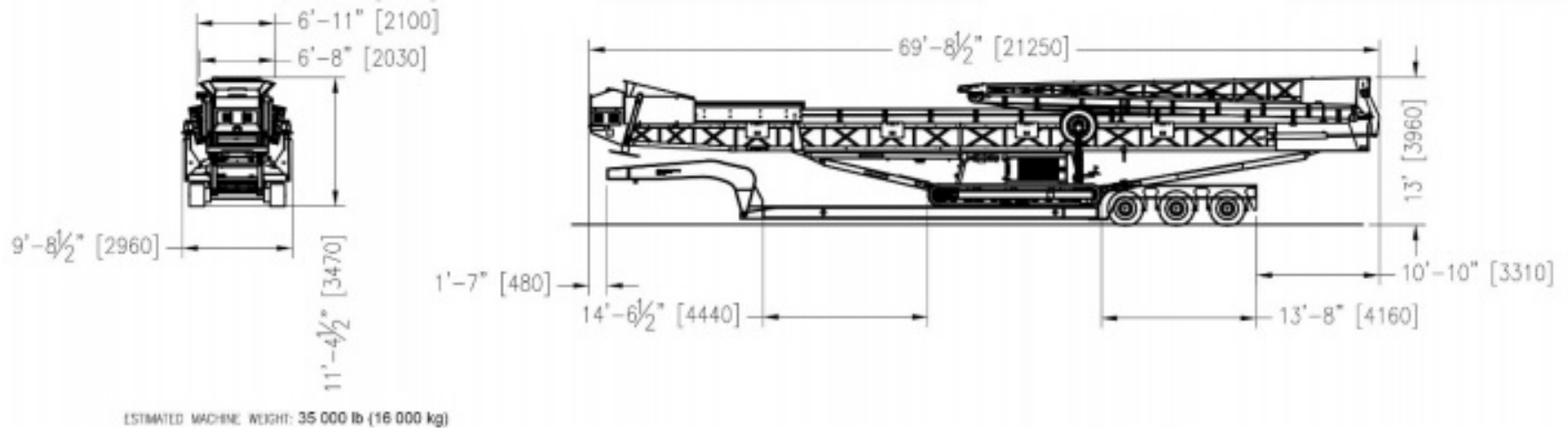

SPECIFICATIONS

Belt Width	36" (900mm)	Track Specs	
Belt Length (Pulley Centers)	100' (30,480mm)	Track Width	1' 3-3/4" (400mm)
Belt Type	Heavy Duty Plain 3-Ply, 3/16" x 1/16"	Track Length (Center-to-Center)	9' 9" (2,970mm)
Drive Pulley Diameter	14" (355mm)	Track Height	2' 5" (594mm)
Trail Pulley Diameter	12" (304mm)	Maximum Speed	0.75 mph (1.2 km/hr.)
Maximum Belt Speed	548 ft/min. (167 m/min)	Working Dimensions (With Lift Axle Option)	
Maximum Conveyor Capacity	500 TPH	Width	20' 7" (6,280mm)
Diesel Engine Size	74 hp (55.0 kW)	Length	105' 2" (32,060mm)
Diesel Tank Capacity	87 US Gallon (330 L)	Height	43' 8-1/2" (13,320mm)
Hydraulic Tank Capacity	116 US Gallon (440 L)	Transport Dimensions	
Working Dimensions		Width	8' 2" (2,490mm)
Width	8' 5" (2,570mm)	Length	51' 8" (15,750mm)
Length	103' 6-1/2" (31,560mm)	Height	11' 3" (3,420mm)
Height	41' 0-1/2" (12,500mm)	Total Weight (approximate)	27,000 lbs (12,300 kg)

ADDITIONAL OPTIONS

Dual Power	ASGCO Scraper	Hopper Extensions	Hopper Wear Plate Liner
Belt Scale	Impact Idlers Under Hopper	Anti-Segregation Paddle Wheel	Landing Gear (Standard with Pivot Point On Lift Axle Machines)
Spray Bar	Magnet Material Separator	Auxiliary Guarding	
Chevron Belt	Lift Axle	Hopper Wing Plates	TimBin - Large Hopper Bin (450ph)